



DUAL BAND BASE STATION ANTENNA

MODEL: TXAB-144-430

Specifications

GAIN	6 dB (2 M) or 8 dB (70 cm) better than quarter wave antenna
VSWR	Less than 1.5:1
FREQUENCY RANGE	144 - 148 (2 M) / 430 -440 MHz (70 cm) OR 144 - 148 (2 M) / 440 -450 MHz (70 cm)
POLARIZATION	Vertical
IMPEDANCE	50 Ohm
CONFIGURATION	5/8 wave 2 element (2 M) 5/8 wave 4 element (70 cm)
POWER CAPACITY	200 Watts
CONNECTOR	SO-239

Assembly

1. Refer to drawing (rear side of this instruction). Install upper radiator element (part #13) onto lower radiator element (part #15) by inserting element joint (part #14) fully onto lower radiator element and tightening set screw (part #16) securely with wrench (part #8).
2. Slide upper outer tube (part #1) into lower outer tube (part #4). Thread upper outer tube joint (part #2) onto lower outer tube joint (part #3) and tighten securely.
3. Put the locking nut and washer onto the ground plane radials, then screw the three radials (part #5) into threaded holes on the metal antenna base (part #6) and tighten them by fingers. Secure the radials by tightening locking nuts with wrench.
4. Secure support pipe (part #10) to mounting pole (not included) in desired location using brackets (part #12), u-bolts (part #11), locking screws (part #7), lock washers (part #8), and either self locking nuts or nuts (part #9) and lock washers (part #8) supplied. Tighten securely with wrench (not included).
5. Run up the cable from radio through supporting pipe (part #10) and screw PL-259 on cable end tightly onto SO-239 connector at the bottom of antenna. Assemble antenna into support pipe with open threaded hole turned so that it will align with hole on support pipe for locking screw. Screw the locking screw (part #7) into hole and tighten it securely with wrench or screw driver.

Adjustment

No adjustment is necessary. Your TXAB-144-430 is pre-aligned at the factory for 144 - 148 MHz and 430 - 440 MHz or 144 - 148 MHz and 440 - 450 MHz

TXAB-144-430 PARTS LIST AND ASSEMBLY DRAWING

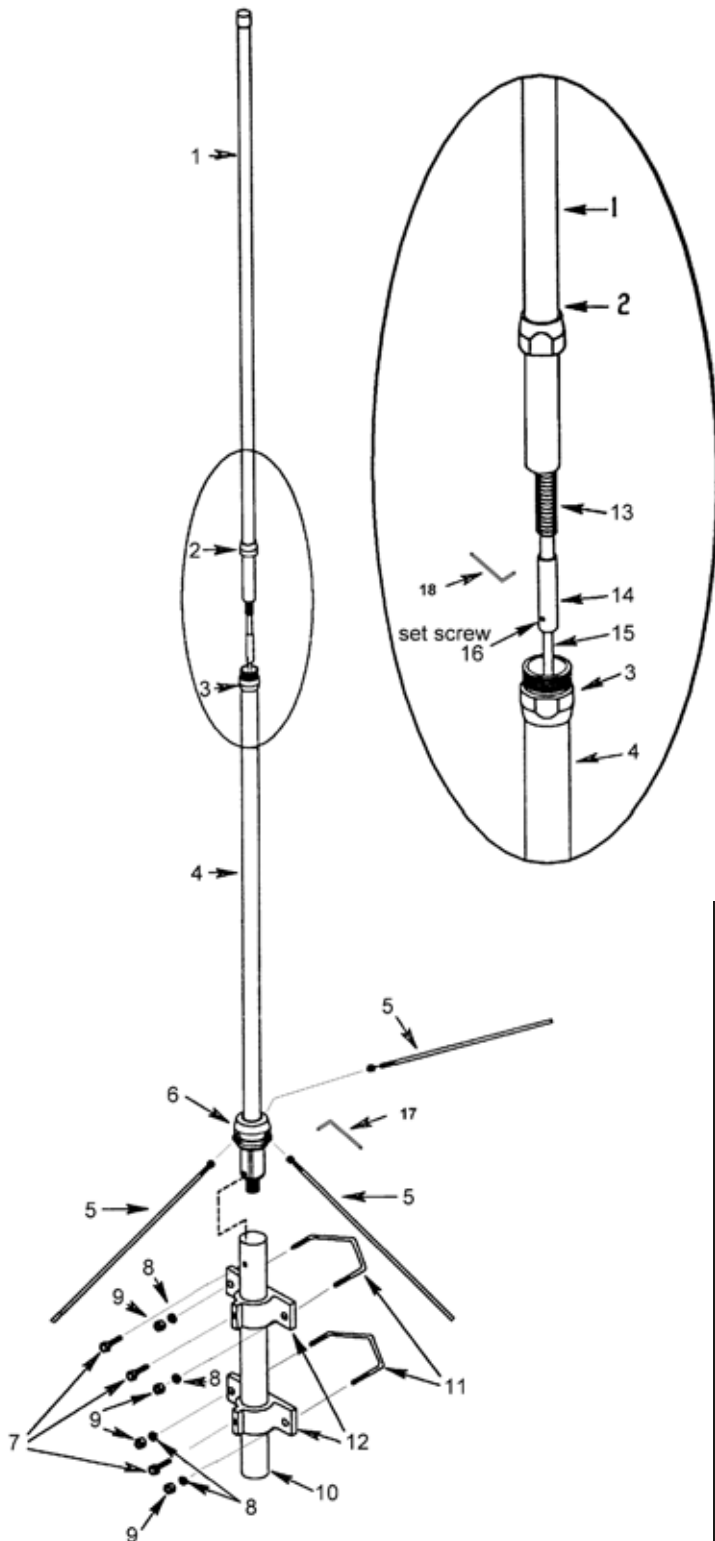

PARTS LIST

NO	DESCRIPTION	Q'TY
1	UPPER OUTER TUBE	1
2	UPPER OUTER TUBE JOINT	1
3	LOWER OUTER TUBE JOINT	1
4	LOWER OUTER TUBE	1
5	RADIALS & NUT, SPRING WASHER	3
6	METAL ANTENNA BASE	1
7	LOCKING SCREW	3
8	LOCKING WASHER	4
9	NUT	4
10	SUPPORTING PIPE	1
11	U-BOLT	2
12	BRACKET	2
13	UPPER RADIATOR ELEMENT	1
14	ELEMENT JOINT	1
15	LOWER RADIATOR ELEMENT	1
16	SET SCREW	1
17	WRENCH (LARGER ONE)	1
18	WRENCH (SMALLER ONE)	1